

# Radianz<sup>®</sup> Floor Installation

RZ-802-2018

## **1. Introduction**

## **2. Manufacturing process**

## **3. Handling of the products**

3.1 Dimension & Weight

3.2 Shipping procedure

3.3 Product storage

## **4. Performance properties**

4.1 Physical properties comparison

4.2 Mechanical & Chemical properties

## **5. Fabrication**

5.1 Health safety information

5.2 Inspection

5.3 Straight cut

## **6. Installation**

6.1 Thickness, sizes and colors, sizes and colors

6.2 Thermal expansion

6.3 Tolerance of the tile dimensions

6.4 Installation of floor and wall tiles

## **7. Material safety**

## **8. Care and Maintenance**

8.1 Preparation for the floor cleaning

8.2 Cleaning for the floor

# 1. INTRODUCTION

RZ-802-2018

Radianz® by LOTTE ADVANCED MATERIALS is a remarkable blend of nature and technology combining natural quartz with advanced polymers. The result is an extremely hard and durable surface with performance and aesthetic characteristics that is superior to that of quarried stone products. Radianz® quartz surface is commonly used in any interior surfacing applications such as floors, walls and premium countertops for homes and businesses.

Radianz® is comprised of more than 93 percent mined quartz crystals, one of the hardest minerals found in nature. Color controlled quartz crystals are blended together with technologically advanced polymers, resulting in a luxurious and smooth high-gloss material that does not require routine sealing.

## Product Features & Benefits

- Stain Resistant
- Chemical and Bacteria Resistant
- Non-porous, Hygienic and Safe
- Easy Clean and Low Maintenance
- Scratch Resistant
- Chip and Crack resistant
- Durable
- Abrasion Resistant

## Main application

- Countertops
- Interior wall cladding
- Shower and tub surrounds
- Table and desk tops
- Toilet compartment partition
- Elevator cab walls
- Stairs
- Door sill (Threshold)
- Vanities and sinks
- Other interior finish

# 2. MANUFACTURING PROCESS

RZ-802-2018

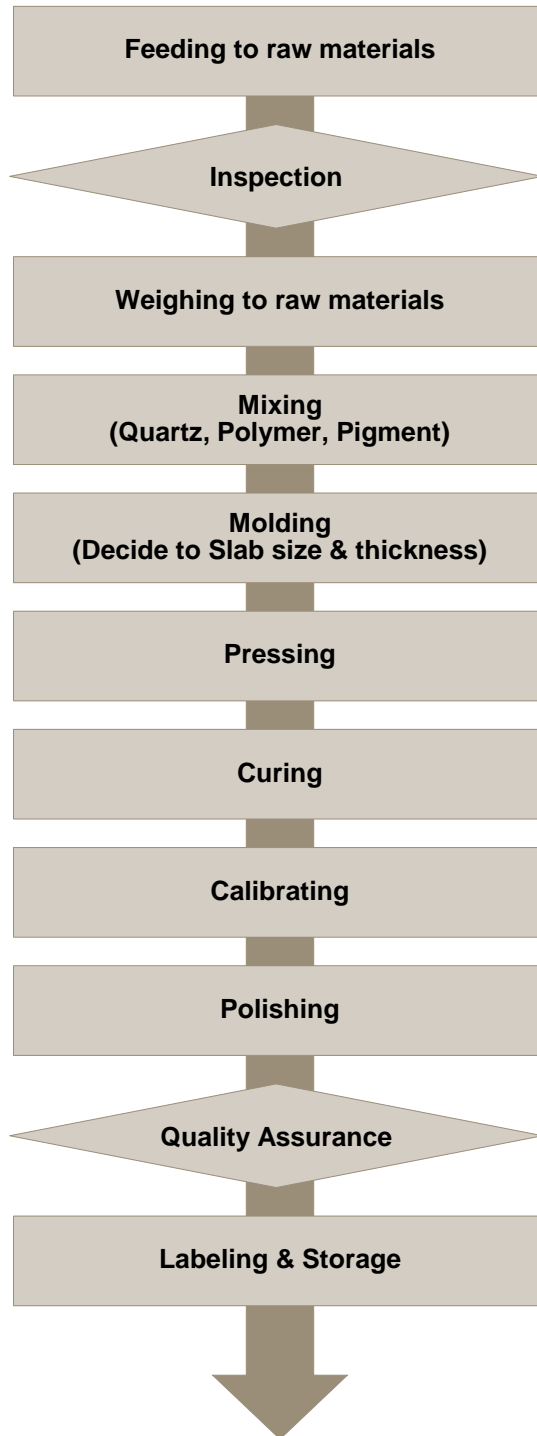

### 3.1 Dimensions & Weights

#### 1) Slabs

Thickness		Width		Length		Weight	
mm	inch	mm	Inch	mm	inch	kg	lbs
12	1/2	1,520	60	3,100	122	141	311
20	3/4	1,520	60	3,100	122	235	518
30	1 1/4	1,520	60	3,100	122	353	778

#### 2) Tiles

Thickness		Width		Length		Weight	
mm	inch	mm	Inch	mm	inch	kg	lbs
12	1/2	600	24	600	24	10.8	23.8
20	3/4	600	24	600	24	18.0	39.7
30	1 1/4	600	24	600	24	27.0	59.5

### 3.2 Shipping procedure

#### Slabs

- 1) Slabs are transported on wooden or metallic frame.
- 2) All surfaces (usable surfaces) are covered by protected film and the finished slabs are placed on face to face.
- 3) Each slab, after quality inspection, is marked with a label containing the following information:
  - Color name / Color code
  - Lot Number with base color indication code (U, H, D)
  - Material code
  - Slab size & Thickness
- 4) Loading capacity of 20ft container

	Thickness		slabs/container
	mm	inch	
A-Frame	12	1/2	126
	20	3/4	76
	30	1 1/4	50

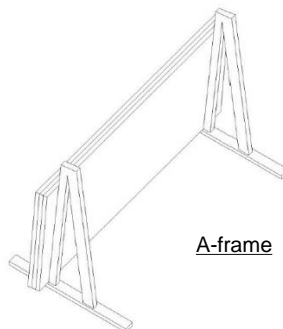

### 3.3 Product storage

1. Indoor storage is recommended for the Product. If the Product is stored outside, they must be kept covered and be stored with the polished faces unexposed. UV light from the sun can react with the plastic resins in the slabs and permanently damage the appearances or change colors. Also, rain or some contaminants may penetrate into the gap between protective film and the surface and can cause staining
2. Please note that outside storage may result in staining, discoloration, deformation, chipping, crack and many other things, thus not recommended
3. While storing or transporting the product, it is necessary to make arrangements so as to protect against damages caused by crushing, improper handling or staining with lubricants, petrol, painting materials, building materials, rust, etc.
4. The first slab or tile against the frame should be the back side and the next sequential slab or tile should be polished face to polished face. Then the following should be back side to back side.
5. Slabs must be stored in the vertical position on the compact stand so that back side of the slab lies with its full area upon backing and so that no part of the slab overlaps to the free area. Lower part of warehouse frames must be provided with rubber, plastic or wooden pads to prevent the chipping of slabs lower edge during manipulation. Slabs are put in stands in bundles that are separated with vertically laid wooden lathes – min. 4 pieces for 20mm and 30mm slabs and min. 6 pieces for 12mm slabs – in even distance all over the length of the slab bundles. If some slabs lean on another slab with gap at the bottom, prolonged storage may cause warping due to pressure.

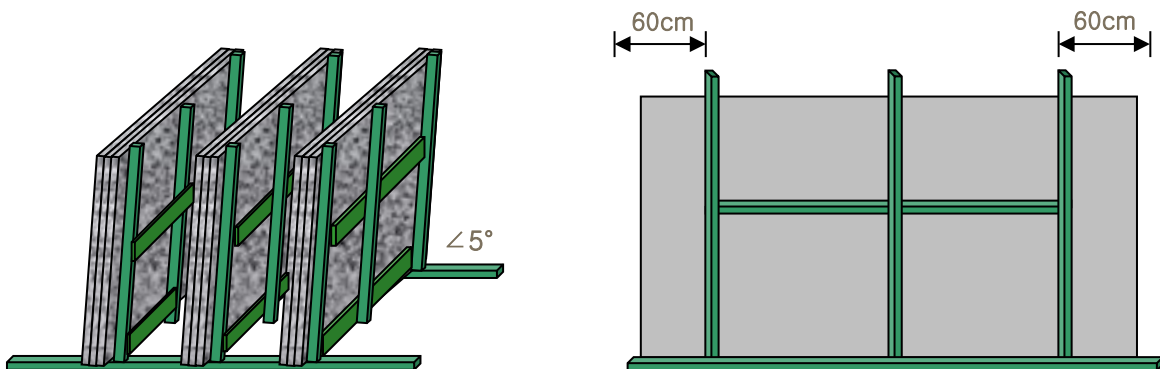

RZ-802-2018

## 4.1 Physical properties comparison

### Water Absorption

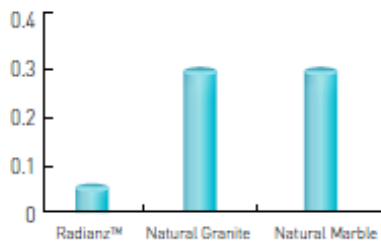

### Specific Gravity

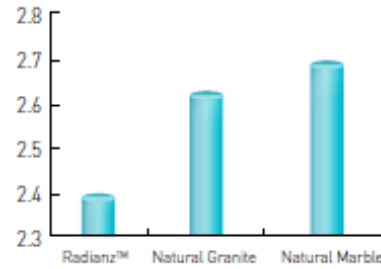

### Compressive Strength

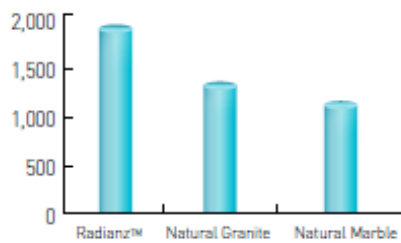

### Flexural Strength

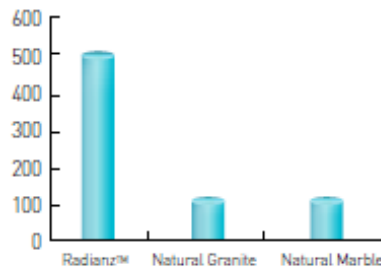

Items	Radianz®	Natural Granite	Natural Marble
Stain Resistance	***	**	*
Abrasion Resistance	***	***	*
Chemical Resistance	***	**	*
Non-Porous	***	*	*
Flexural Strength	***	**	*
Color Consistency	***	**	*
Chip And Crack Resistance	***	***	*
Low Maintenance	***	**	*

\*\*\*: Excellent, \*\*: Good, \*: Fair

## 4-2. Mechanical &amp; Chemical properties

PROPERTIES	TYPICAL RESULTS	TEST PROCEDURE	REMARKS
Specific Gravity	2.41	ASTM D792-08	
Water Absorption	0.03%	ASTM C373-06	
Coefficient of Linear Thermal Expansion	1.35 x 10 <sup>-5</sup> /°C	ASTM D696-03	
Flexural Strength	53.6 Mpa	ASTM D790-07	
Flexural Modulus	11.9 Gpa	ASTM D790-07	
Boiling Water Resistance	No effect	NEMA LD3 2000 3.5	
High Temperature	No effect	NEMA LD3 2000 3.6	
Moh's Hardness	7	MOHS Hardness Scale	
Slip Resistance - Coefficient of Friction (Received: Dry/Wet)	0.91 / 0.49		Neolite
	0.45 / 0.57	ASTM C1028-07	Leather
	1.03 / 0.49		Rubber
Slip Resistance - Coefficient of Friction (Renovated: Dry/Wet)	0.89 / 0.48		Neolite
	0.40/ 0.58	ASTM C1028-07	Leather
	0.92/ 0.50		Rubber
Compressive Strength	DRY: 213.74 Mpa WET: 251.16 Mpa	ASTM C170-09	
Stain Resistance	Passes	ANSI Z124.6-07	
Cigarette Test	Passes	ANSI Z124.6-07	
Chemical Resistance	Passes	ANSI Z124.6-07	
Impact Tests	Passes	ANSI Z124.6-07	
Fungal Resistance	No effect	ASTM G21-96	
Bacteria Resistance	No effect	ASTM G22-96	
Rockwell Hardness	114	ASTM D785-03	
Abrasion Resistance	606mg	ASTM D4060-07	Taber abrasion
Flammability	Class A	ASTM E84-09	

## DISCLAIMER

The information contained herein is provided by LOTTE ADVANCED MATERIALS and its subsidiaries and affiliates (collectively referred to as "LOTTE ADVANCED MATERIALS") for information purposes only and should be used by individuals with technical experience and knowledge in the area. LOTTE ADVANCED MATERIALS does not make any representation or warranties of the usefulness or expected result of the information, and does not assume any responsibility whatsoever related to the use of the information. Exclusion of the implied warranties may not apply in certain jurisdictions.



## 1) Fungal resistance

### (1) TEST METHOD

- **ASTM G 21 :**

: Determining Resistance of Synthetic Polymeric Materials of Fungi

- **Strains:**

Aspergillus Niger (ATCC 9642)  
 Penicillium Pinophilum (ATCC 11797)  
 Chaetomium Globosum (ATCC 6205)  
 Aureobasidium Pullulans (ATCC 15233)

- **Culture condition:**

30 +/- 1 °C, 85%RH, 28days

- **Limitation**

OBSERVED GROWTH ON SPECIMEN	RATING
None	0
Traces of growth (Less than 10%)	1
Light Growth	2
Medium Growth	3
Heavy Growth (60%-to complete coverage)	4

### (2) TEST RESULT

- **Zero traces of growth**

CULTURE TIME	DAY 0	DAY 7	DAY 14	DAY 21	DAY 28
Result	0	0	0	0	0

## 2) Bacteria resistance

### (1) TEST METHOD

- **ASTM G 22 :**

Standard Practice For Determining Resistance of Plastics to Bacteria

- **Strains:**

Pseudomonas Aeruginosa (ATCC 13388)

- **Culture condition:**

36 +/- 1°C, 85%RH, 21days

- **Limitation**

OBSERVED GROWTH ON SPECIMEN	RATING
None	0
Traces of growth (Less than 10%)	1
Light Growth	2
Medium Growth	3
Heavy Growth (60%-to complete coverage)	4

### (2) TEST RESULT

- **Zero traces of growth**

CULTURE TIME	DAY 0	DAY 7	DAY 14	DAY 21
Result	0	0	0	0

### 3) Flammability

#### (1) TEST METHOD

- **ASTM E 84**

Surface Building Characteristics of Building Materials

- **Sample preparation and conditioning:**

Three pieces of sample were placed into the fire chamber end to end supported on screen and rods, to form a 21 inches wide X 24 feet long for testing, than was covered with inorganic cement boards to protect the chamber lid.

- **Test procedure:**

The tunnel was thoroughly pre-heated by burning natural gas. When the brick temperature, sensed by a floor thermocouple, had reached the prescribed 105° Fahrenheit +/-5° Fahrenheit level, the sample was inserted in the tunnel and test conducted in accordance with the standard ASTM E84-09 procedure.

The operation of the tunnel was checked by performing a 10-minute rest with inorganic board on the day of the test.

- **Rating:**

The National Fire Protection Association Life Safety Code 101, Section 6-5.3, "Interior Wall and Ceiling Finish Classification", has a means of classifying materials with respect to Flame Spread and Smoke Developed when tested in accordance with NFPA 255, "Method of Test of Surface Burning Characteristics of Building Materials" (ASTM E84).

FLAME SPREAD	SMOKE DEVELOPED	RATING
0 – 25	0 - 450	Class A
26 - 75	0 - 450	Class B
76 - 200	0 - 450	Class C

#### (2) TEST RESULT

- **Flame Spread : 10**
- **Smoke Developed : 180**
- **Rating : Class A**

## 4) Stain resistance

### (1) TEST METHOD

- **ANSI Z124.6 - Section 5.2** : Stain Resistance

- **Test procedure:**

Two (2) drops of each of the following liquid reagents shall be applied to the surface of Radianz®. Expose the sample for 16 hours; Covered with glass plate and uncovered. The stained specimens shall be subjected to cleanability tests immediately and rated at that time. Each stain, both covered and uncovered, shall be given a number in accordance with the rating procedure given in Table 4.1.

- **Performance Requirement**

The maximum stain resistance rating shall be the sum of all the individual stain ratings for each of the covered and uncovered stain areas. The maximum allowable total rating shall be 64. The maximum allowable thickness of material removed to eliminate the stain shall be 0.012mm.

Table 4.1 – Stain Ratings Procedure

CLEANABILITY TEST	RATING
The specimen shall be washed with tap water and cheesecloth or soft bristle brush using 20 scrub cycles with normal hand pressure and dried by blotting.	1
Stains present after initial wash with water shall be washed with alcohol (commercial rubbing alcohol) or naphtha (lighting fluid) using cheesecloth or soft bristle brush for 20 cycles using normal hand pressure.	2
Stains present after the aforementioned cleanings shall be scrubbed 20 scrub cycles with standard scouring powder and wet cheesecloth or soft bristle brush using normal hand pressure.	3
Stains present after the aforementioned cleanings shall be scrubbed an additional 40 scrub cycles with standard scouring powder and wet cheesecloth or soft bristle brush using normal hand pressure.	4
The affected area shall be lightly sanded with 600grit abrasive cloth until the stain is removed. The depth shall be measured to the nearest 0.025mm.	5

### (2) TEST RESULT

- **Stain Resistance** : Pass
- **Reagent** :
  - Black Crayon
  - Black Liquid Shoe Polish
  - Blue Washable Ink
  - Gentian Violet Solution
  - Beet Juice
  - Grape Juice
  - Lipstick
  - Hair Dye
  - Iodine Solution
  - Wet Tea Bag

## 5) Chemical resistance

### (1) TEST METHOD

- **ANSI Z124.6 - Section 5.5** : Chemical Resistance

- **Test procedure:**

Two(2) drops of each of the following liquid reagents shall be applied to the surface of Radianz®  
Expose the sample for 16 hours ; Covered with glass plate and uncovered

- **Performance Requirement**

The surface finish shall be unaffected by the reagents except for superficial surface change which are removable by sanding with 600 grit wet or dry sandpaper and water. Any resulting damage shall not impair the serviceability of the unit, and shall be easily repairable by using abrasive and polishing compounds to approximate the original finish.

### (2) TEST RESULT

- **Chemical Resistance** : Pass

- **Reagent** :

- Naphtha
- Ethyl Alcohol
- Amyl Acetate
- Ammonia, 10%
- Citric Acid, 10%
- Urea, 6% (Urine)
- Hydrogen Peroxide, 3%
- Sodium Hypochlorite
- Toluene
- Ethyl Acetate
- Lye, 1%~2% (Drano)
- Acetone
- Trisodium Phosphate, 5%
- Vinegar
- Pine Oil
- Phenol, 5% (Lysol)

## 5.1 Health safety information

Information hereunder provides the most important safety issue pertaining to the fabrication and installation. Please read this carefully to understand how silica dust could cause silicosis and severely and permanently damage your health.

Quartz is a pure mineral that has the chemical formula SiO<sub>2</sub> and is crystalline and transparent in structure. Radianz® is composed of 93% quartz by weight. No inherent health risks are present in its slab form. However, respirable crystalline silica dust represents a potential health hazards when they are inhaled by a person. The silica dust are created during all operations done dry such as sawing, sanding, drilling or routing. Dry sweeping can also create silica dusts and cause for developing to silicosis.

Overexposure of silica dust can cause silicosis by the formation of scar tissue in the lungs. Silicosis can be disabling, nonreversible and sometimes produce fatal lung disease. Symptoms of silicosis include coughing, difficulty in breathing and progressive impairment of lung function.

Shop operation in a wet environment using proper ventilation and filtration systems would keep any deadly dust airborne for inhaling and prevent shop employees from potential health risks.

### Personal Protection

- Wear safety glasses
- Wear leather or cotton gloves
- Air purifying respirator

## 5.2 Inspection

The goal at LOTTE ADVANCED MATERIALS is to provide the highest quality materials to our fabricators to insure customer satisfaction. As a result, we check and recheck each individual slab during the inspection process to meet our rigorous quality standards. In addition, it is the fabricators' responsibility to conduct a visual inspection for defects for every slab they work with.

### Check List for Visual Inspection(prior to fabrication)

- Slab-to-slab color match
- Color consistency within slabs
- Holes
- Blotches(Irregular spot)
- Hair crack
- Foreign material
- Thickness
- Polishing mark
- Deformation(warpage) : Deformation should be checked using a full-length straight-edge when the slab is placed horizontally.

The fabricator should contact their distributor for any defect found on the slabs if it will increase fabrication time. Your authorized distributor will answer any question and provide assistance on Radianz® slabs. If you are unsure of the quality of the material, please contact your distributor for service

Please remove the protective film before fabricating. If you do not remove the protective film before fabrication, it may leave water marks from fabrication. LOTTE ADVANCED MATERIALS will replace the slab that does not meet the product specification. However, LOTTE ADVANCED MATERIALS will not be responsible for any labor charges incurred for fabrication done on the defective materials.

## 5.3 Straight cut

### 1) Straight cut tools

- Bridge Saws
- Rail saw – including 12'(3.5m) and 7.5'(2.2m) rails
- Revolution of saw
  - The revolutions of the cutting blade can be different according to the specifications of Bridge machine and saw.

Diameter	300mm(12")	350mm(14")	400mm(16")
rpm	≅ 1,780	≅ 1,540	≅ 1,340

- Cutting speed : < 3.0m/min (Thickness : 20mm)  
< 2.0m/min (Thickness : 30mm)
- Cutting saw
  - Required engineered stone blade should be used.
  - Granite cutting saw : Unacceptable (Risk of crack)
  - Marble cutting saw : Partially allowed but consumption of the blade can be high.

- \* **Manual cutting is not recommended.**
- \* **All fabrication must be done in wet operation.**

### 2) Recommended for cutting Radianz® to minimize crack during fabrication

- Use required engineered stone blade for cutting.
- Should not move during the cutting process when using saw blade.
- Working table should be flat.
- Do not plunge cut. Always start from the outside. When doing sink cut-outs or cook-top cut-outs, it is highly recommended to do such cut-outs after other necessary fabrication such as cutting.
- Do not stop in the middle of cutting process
- Enough water should be used at all time during cutting.
- There should be no bevel edge cracking
- Recommended cutting speed are as follow: THK.20 : 3m/min, THK.30 : 2m/min
- Keep the blade sharp by running the blade through sandstone off cuts.
- Using portable circular saw has high chance of causing crack during cutting.

## 6.1 Thickness, sizes and colors

### 1) Appropriate thickness for each size

Max. size	Thickness
300 X 300(mm)	12mm,20mm
400 X 400(mm)	12mm,20mm
600 X 600(mm)	20mm,30mm

### 2) Recommended colors depending on the application area

Application	Color name
Interior wall	All colors
Interior floor	<p>White color and dark black color products is can only be installed where is expecting no heavy traffic and frequent maintenance care.</p> <p>Please note that white color products can be easily contaminated due to the characteristics of bright colors and scratch marks on dark black color products can be easily seen.</p>

- **All products are recommended for interior use only.**
- Being made from natural materials, the color variations of the product could appear. The Product is sorted by producer according to the basic color standards. Slight optical color differences are proper and should be respected. There is mostly one color shade packed on one pallet and always one color shade in the same cardboard box and the respective lot No. and color shade is given on the box label. In spite of the fact, before starting the installation it's necessary to open several boxes with the tiles, lay the tiles on the floor under natural light and check the color consistency. To avoid any problems with color consistency on the floor is recommended to lay down the tiles consecutively one by one from several checked open cardboard boxes, simultaneously, not only from one card board box.



## 6.2 Thermal expansion

The polyester resin used as a binder causes not only the increase in the high bonding strength properties, but also in the thermal expansion of the product. Therefore, it is necessary to take these facts into consideration during designing the floors and wall claddings.

Linear thermal expansion to differential Radianz® tile sizes		
Tile sizes	Calculation	Length difference
12" x 12" (300 x 300mm)	$1.35 \times 10^{-5}/^{\circ}\text{C} \times 60^{\circ}\text{C} \times 300\text{mm}$	0.243 (300.243)mm
16" x 16" (400 x 400mm)	$1.35 \times 10^{-5}/^{\circ}\text{C} \times 60^{\circ}\text{C} \times 400\text{mm}$	0.324 (400.324)mm
24" x 24" (600 x 600mm)	$1.35 \times 10^{-5}/^{\circ}\text{C} \times 60^{\circ}\text{C} \times 600\text{mm}$	0.486 (600.486)mm

\* Length difference (L) =  $\alpha \times (T2 - T1) \times L0$  (Maximum temperature range : 60 °C)

T1 : Initial temperature(°C)

T2 : Final temperature(°C)

L0 : Initial length(mm)

$\alpha$  : Thermal expansion coefficient (Radianz® :  $1.35 \times 10^{-5} / ^{\circ}\text{C}$ )

Radianz® should be installed by keeping the joint from 3 up to 7 mm according to the characteristics of the base, the sizes, dimensional stability, and thermal expansion coefficient of the product and according to the environment where the installation takes place.

The expansion joints need to be brought through to the tile surface and treated with a flexible sealant. An architect and engineer should be consulted when specifying expansion joint placement, construction and materials.

## 6.3 Tolerance of the tile dimensions

	Tolerance	Remarks
<b>Size</b>	± 1.0mm	- Length and width
<b>Thickness</b>	± 1.0mm	
<b>Flatness</b>	1mm/1m	- Central & Side deformation - Torsion

## 6.4 Installation of floor tiles

### 1) Preparation

- A. Check the substrate (mostly concrete or mortar) prior to install Radianz. It should be level, free from structural movement and clean. Substrate concrete base must be adequately cured before installation. (water content less than 5%)
- B. In case of concrete construction work, it takes 4 weeks for curing perfectly. During 15 days after apply concrete, working site's temperature and humidity should be controlled preventing frost or drying so fast.
- C. If concrete substrate is not even enough, self leveling process with mortar might be applied.

### 2) Adhesive

- A. Exclusive adhesive is required to bonding Radianz on concrete substrate. Cement is common adhesive for natural stone but it is not suitable for Radianz because water based cement's bonding strength is weak to Radianz which has low water absorption property.
- B. Recommended Adhesive: Latex modified thin-set mortar.
  - Product name: Platinum rapid (Laticrete), Grani rapid (Mapei)
  - Use : All standard installation of floor
  - Characteristics : Fast setting, allow grouting in 3 to 4 hours.
  - Color : White & Grey
  - Thickness of mortar : up to 10mm

#### Manufacturer's information

- LATICRETE International : <http://www.laticrete.com>
- MAPEI International : <http://www.mapei.com>

### 3) Installation

- A. Keep the temperature of the installation site at 5 to 30°C for more than 24 hours before installing Radianz.
- B. Keep the temperature around 20°C and relative humidity below 75% during the job.
- C. Prepare a mixture of adhesives according to the mixing ratios recommended by manufacturer. When mixing, the mixer drill is much easier to work with. The amount of mixing varies depending on the material but consider that the mixture should be used within 1 hour.
- D. Apply the adhesive evenly to the substrate with a notched trowel and apply adhesive on backside of Radianz about 1mm thickness. If the adhesive is too thick, the adhesive may be sagged and the bonding strength might be lowered. Therefore, the adhesive thickness between sheet and substrate should not exceed 10 mm.
- E. Place the product on it, check the level, and tap it with a rubber mallet to secure it firmly.
- F. Remove any foreign matter on the product surface with a wet sponge.
- G. Grouting should be applied after 24 hours placing Radianz.
- H. When the work is completed, protect it with plywood or corrugated paper to prevent the construction surface and movements, and prohibit the passage for at least 24 hours.

*\* This process is a general information about thin-set method. Please consult with the adhesive supplier for more detailed installation manual.*

#### Caution!

The product should avoid exposure to cement paste or mortar. Prolonged exposure to cement with high alkali can cause discoloration of the product. Cement paste or mortar have strong alkaline chemical (pH 12~13).

# 6. INSTALLATION

RZ-802-2018

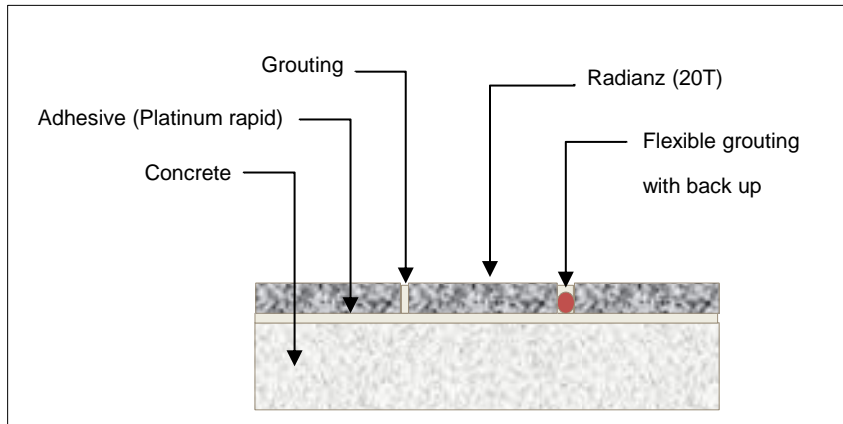

< Installation: Thin-set method on self leveled substrate >

## 4) Expansion gap

- A. All materials, including Radianz and natural stone, have thermal expansion properties. When installing the floor application, it should be done considering shrinkage and expansion. The thermal expansion coefficient of Radianz is about  $1.35 \times 10^{-5} \text{ mm/mm } ^\circ\text{C}$ , and it varies from color to color. Considering this, Expansion gap should be applied at least once every 4m. Please refer to this document chapter 6.2 for calculating expansion. The grouting of the expansion gap shall be made of a flexible material capable.



< Expansion gap >



< Expansion problem case: Left: E-stone, Right: Natural stone >

### 5) Leveling system and spacer

- A. The leveling system and spacer may help the work to adjust Radianz flooring tile easier and more accurate.

*\* Please consult with the leveling system supplier for more detailed installation manual.*

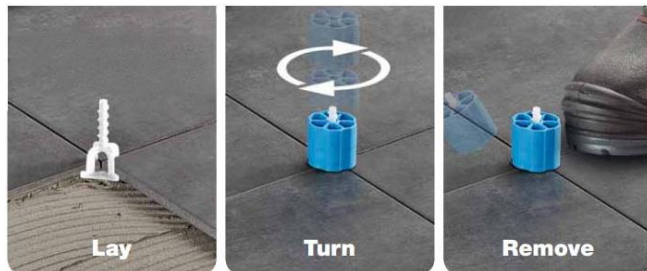

### 6) Grouting

- A. It should be avoided that installing without any space between the tiles. Considering the thermal expansion of the product, a minimum 2 mm for tiles (400 mm × 400 mm) and a minimum 3 mm for tiles (500mm x 500mm) space should be provided between tiles.
- B. Before grouting, remove mortar residue, foreign matter, etc. at joint gap completely. In case of mixing colorant in grouting material, it is necessary to perform pre-test before work and check whether it stains Radianz or not. It is recommended that grouting be filled lower level than the Radianz level. Make sure that it is filled completely without any void.
- C. Remaining grouting material on the Radianz may leave damages on the product. Please remove it immediately using a wet sponge.
- D. There are many types of grouting such as anti-fungi, anti-stain, and elastic joints. Select a suitable grouting product for your application. Considering the thermal expansion characteristics of the Radianz tiles, it's better to use flexible grouting material that can withstand expansion.

#### NOTE.

*Following issues will not be covered by Radianz warranty. Such as 1) discoloration by cement, 2) falling off and warping after installation, 3) scratch, stain and crack by user.*

## 6.5 Installation of wall tiles

### 1) Wall

#### A. Environment condition

Product should always be installed according to local codes, ordinances, trade practices and climatic conditions. There are almost no restrictions on interior installations of Radianz®. However, until further testing is completed, it is NOT recommended that Radianz® be installed on exterior surfaces.

#### B. Substrate preparation

The surface must be free of coatings, oil, wax or anything that would prevent proper bonding.

#### C. Installation indication

Generally, that can be classified 2- types of setting material considered for Radianz®.

##### ① Organic glued set

- Recommended height up to max. 2.5 m

- Recommended dimensions of the product (cm) Recommended thickness of the product : 300mm x 300 x 12mm

##### ② Anchors System

In the case of larger size, 3/4"(20mm) thickness material will be the selection of choice for a wall installation. Large format panels can be "anchored" to the wall using any of the approved anchor systems available.

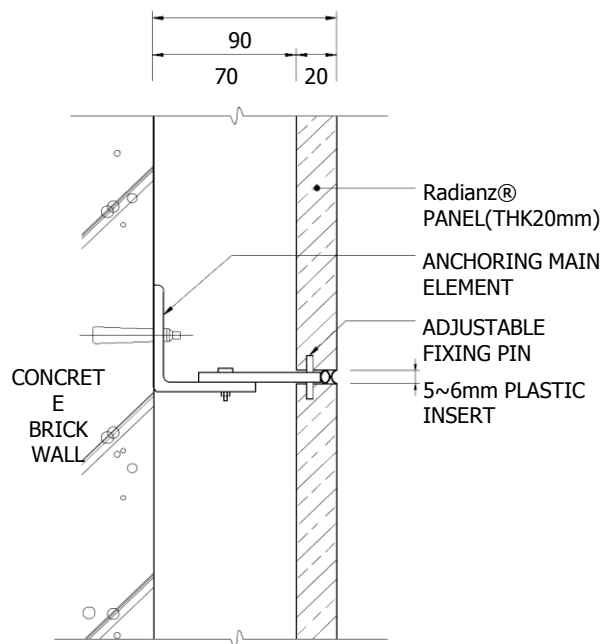

#### D. Protection

① Protect finished work against weather, freezing and immersion in water for at least 21 days after completion of the work.

② Protect walls from impact, vibration and hammering on adjacent walls for at least 14 days after installation.

#### E. Grouting and Jointing

On walls, install Radianz® tiles leaving a regular even spacing between tiles of at least 1/8"(3.0mm). In the case of large areas, for larger tiles or higher mechanical or thermal load, the width of the joint has to be 5 – 7 mm and the joint after each 5th – 6th tile should be jointed by a silicone jointing material.

## 1. Product and Company Identification

- **PRODUCT NAME:** Radianz® Quartz Surfaces
- **COMPANY:** LOTTE ADVANCED MATERIALS
- **EMERGENCY TELEPHONE:** +82-61-689-1114
- **ADDRESS:** 32-2, Gocheon-Dong, Uiwang-Si, Gyeonggi-Do, Korea 437-711

## 2. Composition/information on ingredients

- **CHEMICAL FORMULA:** Not applicable
- **MOLECULAR WEIGHT:** Not applicable
- **DANGER RISK:** Not applicable
- **CAS NUMBER:** 1317 - 65 - 3  
14808 - 60 - 7
- **CE NUMBER:** Not applicable
- **EINECS NUMBER:** Not applicable

Product in composite stone obtained by mixing of quartz granules and/or silica sands bound with polyester resin.

## 3. Identification of Dangers

Avoid inhaling dust generated during fabrication. Inhalation of dust composed of Radianz® may cause irritation to the mucosa. Continued exposure to crystalline silica may cause silicosis, a chronic and progressively debilitating lung disease.

## 4. First Aid Measures

- **SKIN CONTACT:** Normally no effect. May cause dryness of the skin with prolonged contact.
- **EYE CONTACT:** Normally no effect. In case of contact, flush with water. In case of continued pain, consult your medical care provider.
- **INGESTION:** In case of ingestion (see 3, above), immediately rinse the mouth with water and consult your medical care provider.
- **INHALATION:** In case of inhalation (see 3, above), move to an open and well-ventilated area. Consult your medical care provider.

## 5. Fire Safety Measures

- **APROPRIATE FIRE EXTINGUISHERS:** All fireproof means and materials are suitable.
- **NON-APPROPRIATE EXTINGUISHER, MEANS AND MATERIALS:** None
- **RISK OF COMBUSTION:** Radianz® is a non combustion product.
- **MEANS OF PROTECTION:** None

## 6. Measures in Case of Accidental Spillage

- **INDIVIDUAL PRECAUTIONS:** Use personal protective equipment.
- **ENVIRONMENTAL PRECAUTIONS:** None
- **CLEANING METHOD:** Use manual or mechanical equipment.

## 7. Manipulation and Storage

- **PRECAUTIONS FOR MANIPULATION :** None
- **PRECAUTIONS FOR STORAGE:** Store in ventilated areas, covered and protected from heat.

## 8. Exposure Controls/Individual Protection

- **TECHNICAL MEASURES :** See 7, above
- **INDIVIDUAL PROTECTION DEVICES (IPD):** Individual protection is required if dust is generated.
  - PROTECTION OF RESPIRATORY SYSTEM: Wear a dust mask.
  - PROTECTION OF HANDS: Wear protective gloves.
  - PROTECTION OF EYES: Wear protective glasses.
  - PROTECTION OF THE SKIN: None

Operating in a wet environment, combined with the use of ventilation and filtration systems are effective exposure controls.

## 9. Physical and Chemical Properties

- **PHYSICAL STATUS:** Solid
- **FORM:** Not applicable
- **COLOR:** Various
- **ODOR:** None
- **pH:** Not applicable
- **BOILING TEMPERATURE :** Not applicable
- **FUSION TEMPERATURE :** Not applicable
- **FLASH POINT :** Not applicable
- **AUTO-INFLAMMABILITY :** Not applicable
- **COMBURENT PROPERTIES :** Not applicable
- **STEAM PRESSURE :** Not applicable
- **DENSITY AT 20°C :** 2.48 - 2.50 kg/dm<sup>3</sup>
- **SOLUBILITY :** Insoluble in water and in inorganic acid
- **COEFFICIENT N-OCTANE/WATER :** Not applicable

## 10. Stability and Reactivity

- **CONDITIONS TO AVOID** : None
- **MATERIALS TO AVOID** : None
- **DANGEROUS PRODUCTS OF DECOMPOSITION** : None

## 11. Toxicological Information

- **MEANS OF PENETRATION** :
  - INGESTION : No
  - INHALATION : Yes
  - CONTACT : No
- **ACUTE TOXICITY** : No
- **CHRONIC TOXICITY** : Yes
- **CORROSIVITY / IRRITATION PROPERTIES** :
  - SKIN: None
  - EYES: None
  - RESPIRATORY: Possible chronic effects of long-term exposure - silicosis, pulmonary emphysema.
- **SENSITIVITY PROPERTIES** : Unknown

## 12. Ecological Information

- **MOBILITY** : None
- **PERSISTENCE/DEGRADABILITY** : Not persistent/degradable
- **BIOACCUMULATION** : None
- **ECO-TOXICITY** : None

This product is considered a stable material, non reactive and insoluble. Based on current knowledge, non-ecological problems are hypothesized. Use according to good working procedures, and avoid the dispersal of particulate material into the environment.

## 13. Consideration of Refuse

- **CONTAINMENT TECHNIQUES** : No requirements
- **CLEANING TECHNIQUES** : Manual removal (shovel, broom, vacuum cleaner)
- **BIOACCUMULATION** : None
- **SCRAP MATERIAL DISPOSAL**: Disposal of fabrication and installation waste materials must be handled in accordance with existing regulations regarding waste materials.
- **Packaging Material Disposal**: Recycle or reuse packing materials (carton and wooden pallets).  
Dispose of external wrapping according to existing regulations.



RZ-802-2018

## 14. Transport Information

- **GROUND** : No specific precautions
- **WATERWAYS** : No specific precautions
- **SEA** : No specific precautions
- **AIR** : No specific precautions

## 15. Regulatory Information

Radianz® is not dangerous as per Italian Decree Law, 3 February 1997 n.52 and relative rules regarding the classification, packaging and labeling of dangerous substances.

## 16. Other information

We hereby certify that the above statements are true and correct in every respect.

If the statements are not true, all responsibility will belong to LOTTE ADVANCED MATERIALS.

Signature/Issued Date:

**Radianz® Quartz Surfaces**  
**LOTTE ADVANCED MATERIALS**

Radianz® quartz surface is made from good quality raw materials that present exceptional physical and mechanical features with unique beauty ideal for interior decoration. It requires very little maintenance as its unique production process creates a surface with low porosity, which prevents fluid absorption. The hardness of the surface (6 –7 grade according to Mohs) and a very low water absorption make the product highly resistant to common influences. However, the protection of the product surface under a long-term exposure to abrasive impurities is the reason for recommending the regular maintenance and cleaning of the product surface.

### 8.1. Preparation for the floor cleaning

Before using chosen cleaning or protecting agent it is necessary to test it on a small area and only after the evaluation of the results on a dried-up product to carry out the overall application. Most of the agents are to be diluted according to the instructions of their producers. After using cleaning agents, it is always necessary to remove the cleaning agent and release impurities from the product surface quickly and carefully and to wash the surface thoroughly with pure water.

The product surface does not resist in the long term exposure to strong alkaline (NaOH, KOH , ...) and does not resist even in the short term to the hydrofluoric acid (HF). These chemicals are contained in some cleaning agents, which are available on the market. Therefore, for cleaning the

surfaces it is important to use only products, which are suited for the cleaning of engineered stone; They may not be identical to the cleaning agents for natural granites or ceramics. For cleaning, especially after the installation and jointing of floor tiles or for the cleaning of the tiles, which are highly dirty in the long term, use recommended products and not the mixtures of chemicals (lye, hydrochloric acid, hypochlorite...). The cleaning and maintenance, especially of larger surfaces, are recommended to be realized by specialized company experienced in maintenance of the engineered stone. It is necessary to use protecting instruments according to the instructions from their producers.

### 8.2. Cleaning for the floor

An appropriate cleaner is applied to the surface of the product (best done by machine, always with PAD disks). Any residual cleaner should be cleaned when the released impurities are carefully removed. When polishing-over is done by a machine it is always necessary to use only

the disks with artificial fibers (e.g. PAD LUX) to assure proper cleaning process. (Avoid usage of any type of steel wires disks since it may cause scratches)

Radianz® is substantially harder than natural stone and highly resistant to scratch. However, avoid abusing the surface by refraining from using sharp objects such as sharp knives or screw drivers directly onto the surface.

#### Recommended equipment for floors cleaning

- One-disk floor washer with 150 – 200 rpm (for all operations)
- Water vacuum cleaner or water extractor
- Nylon pads with boar's hair (for washing), White PAD LUX (for polishing)

#### [Products that should be avoid ]

- Cleaners that contain Pine Oil. Without very thorough rinsing, these products can leave behind a residue of pine oil. The pine oil then attracts and holds dirt on the surface, eventually reducing the cleanliness of the surface and its appearance.
- Highly aggressive cleaning agents such as oven/grill cleaners and dishwasher polishing agents that have high alkaline/pH levels (pH 8.5 or higher)
- Abrasive scrubs/cleaners containing either soft or hard abrasive particles. The abrasives will harm Radianz® and if the surface is not completely rinsed, a powder residue will remain reducing the appearance of the surface, especially on dark colors.
- Cleaners that contain xylene, toluene, potassium hydroxide or caustic soda.
- Paint removers, Furniture strippers containing trichlorethane or methylene chloride.